

PAVED AREAS

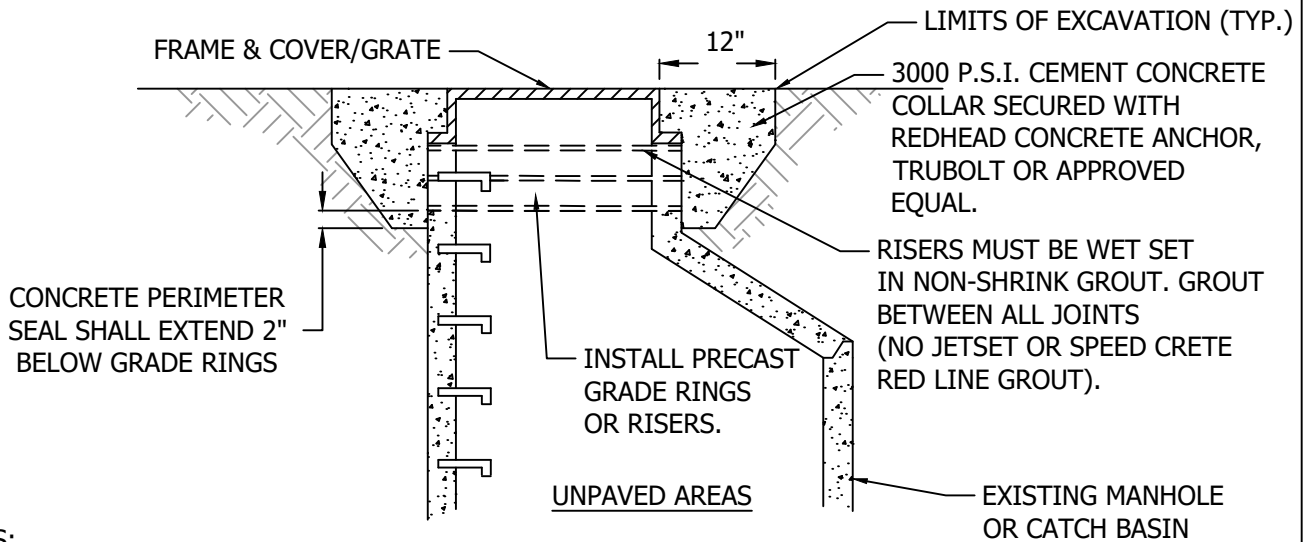

UNPAVED AREAS

**NOTES:**

1. WHERE DEPTH OF NECK EXCEEDS 18 INCHES (INCLUDING FRAME AND COVER), ADJUST MANHOLE/CATCH BASIN TO GRADE BY INSERTING NEW BARREL SECTION BETWEEN THE CONE/SLAB AND EXISTING BARREL.
2. GRADE RINGS, RISERS AND FRAME SHALL BE SET IN 3/4" NON-SHRINK GROUT, GROUT BETWEEN ALL JOINTS. ALL SURFACES MUST BE CLEAN OF DEBRIS AND DIRT, AND WETTED PRIOR TO GROUTING. GROUT SMOOTH INSIDE AND OUTSIDE SURFACES PRIOR TO BACKFILL.
3. STEPS OR HAND HOLDS SHALL BE ADDED PER ASTM C478.
4. PRECAST GRADE RINGS AND RISERS MUST BE CAST WITH GROOVE TO ALLOW FIELD INSTALLATION OF SAFETY STEP WHEN RISER IS 4" OR HIGHER.
5. REPLACE EXISTING FRAME AND COVER/GRATE IF NOT MEETING CURRENT SPECIFICATIONS.
6. IF REQUIRED: LOCKING MH SHALL BE POSITIONED WITH ONE LUG CENTERED OVER STEPS, UNLESS USING CK-S.16A CASTING.

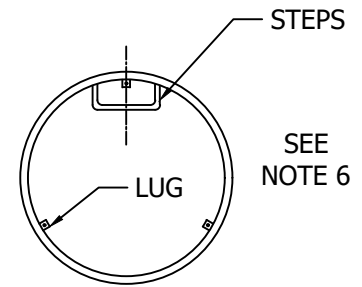

LOCKING MH FRAME  
PLAN VIEW

|   |   |
|---|---|
| <b>CITY OF KIRKLAND</b>   |   |
| <b>PLAN NO. CK - S.26</b>   |   |
|  <p>CITY OF KIRKLAND<br/>WASHINGTON</p> | <b>MANHOLE<br/>FRAME AND GRATE<br/>ADJUSTMENT</b> |