

TYPICAL SECTION FOR CURB & GUTTER, TYPE A

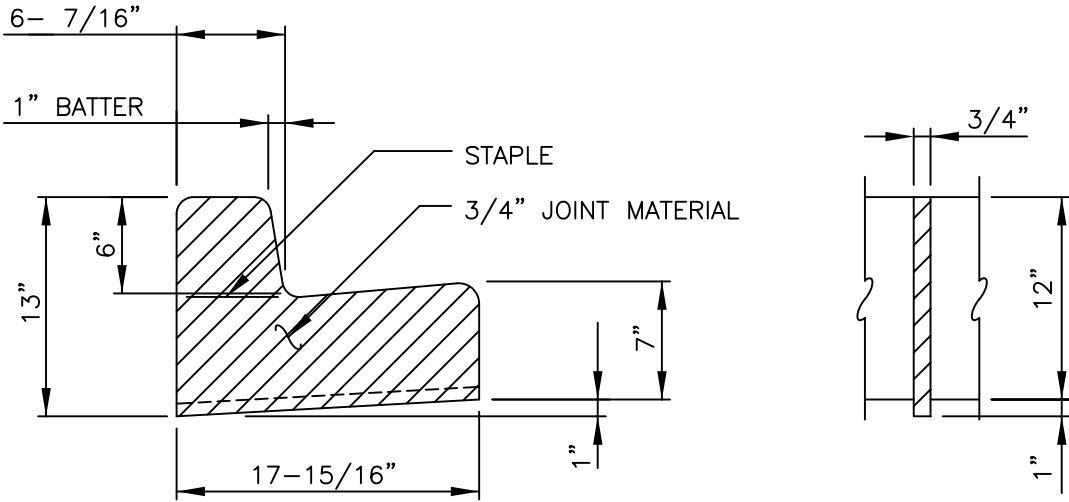

JOINT DETAIL

NOTES

- 1. FORMS SHALL BE STEEL AND SET TRUE TO LINE AND GRADE (INSPECTION IS REQUIRED PRIOR TO PLACEMENT OF CONCRETE).
- 2. CONCRETE SHALL BE CEMENT CONCRETE CLASS 4000.
- 3. BASE COURSE SHALL BE 4" OF 5/8" MINUS CRUSHED ROCK.

CITY OF KIRKLAND	
PLAN NO. CK-R.17	
	<p>CONCRETE CURB AND GUTTER, TYPE "A"</p>